



victrex<sup>®</sup>

PASSION • INNOVATION • PERFORMANCE

# **Victrex® PEEK™ –** **High-performance thermoplast for** **steering and suspension applications**

Vehicle Dynamics Expo 2007

Ralf Weidig  
Global Automotive Manager

**Victrex plc**

# VICTREX at a Glance

- Global company
- > 500 employees
- Turn over in 2006 → 122.5 Mio. GBP
- PAEK capacity 2.800 t/a
- Production ISO 9001:2000 certified
- Second stand alone plant with 1.450 t/a by 4Q07
- More than 25 years experience with the high performance polymers  
VICTREX® PEEK™ und VICTREX® PEEK-HT™



# General Properties of VICTREX® PEEK™

In most applications, it is a combination of three or more of these properties that dictates the use of VICTREX PEEK polymer.

Excellent Hydrolysis Resistance

High Temperature Resistance

High Wear Resistance

Good Electrical Properties

High Purity

High Radiation Resistance



Ease of Processing

FDA Approval

Excellent Chemical Resistance

Good Flame, Smoke and Toxicity

PASSION • INNOVATION • PERFORMANCE



# Thermal properties

	PEEK™	POM
• melting point $T_m$	340°C	166 °C
• glass transition temperature $T_g$	143°C	- 40 °C
• relative temperature index RTI	260°C	110 °C
• heat distortion temperature HDT (1.82 MPa)		
• unfilled	152°C	104 °C
• fibre reinforced compounds	> 300°C	160 °C
• coefficient of thermal expansion		
• unfilled (< $T_g$ )	$4.7 \times 10^{-5}$	$11 \times 10^{-5}$
• filled (< $T_g$ )	$1.5 \times 10^{-5}$	$4 \times 10^{-5}$

# Heat distortion temperature

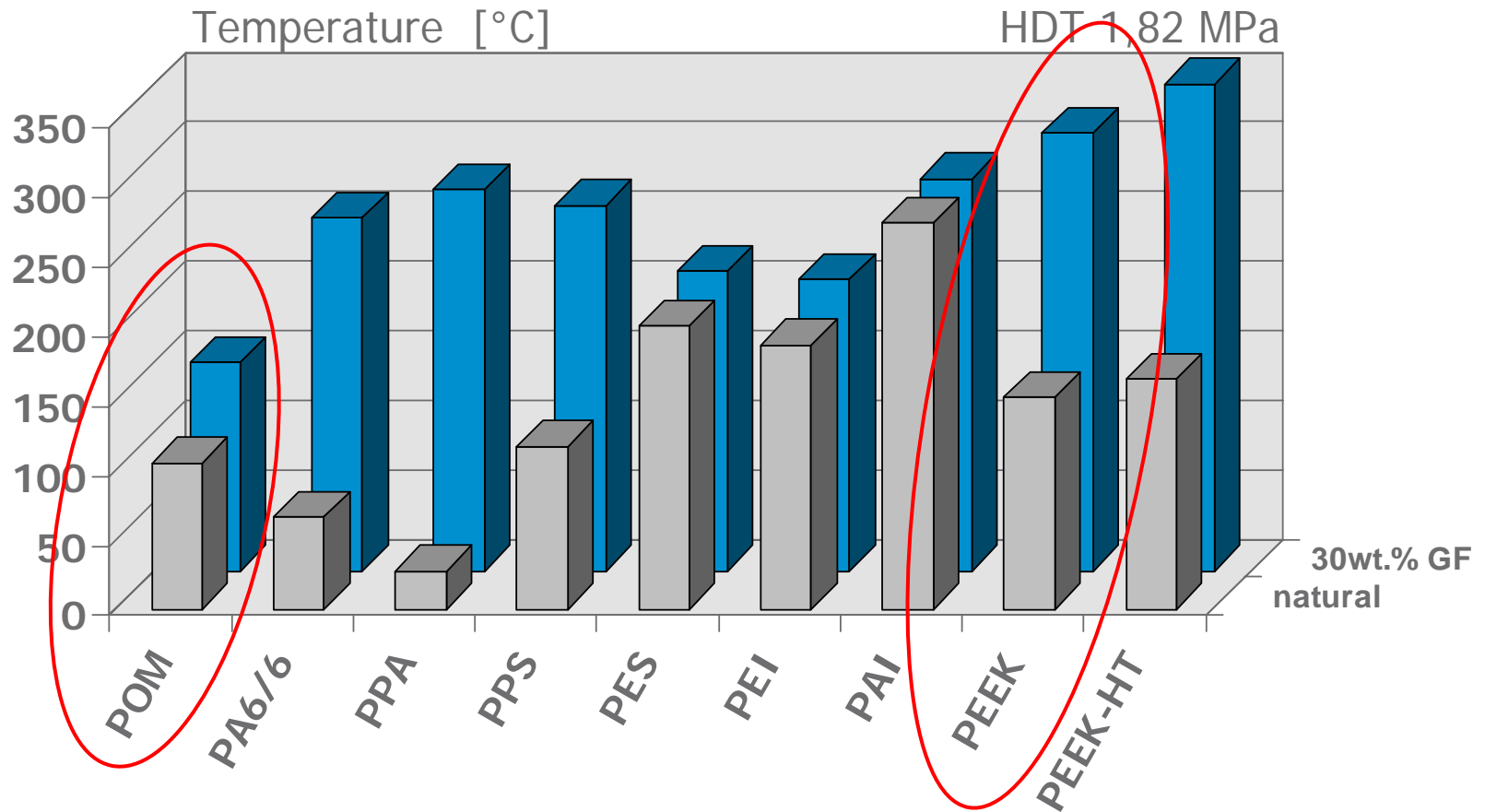

# Relative temperature index

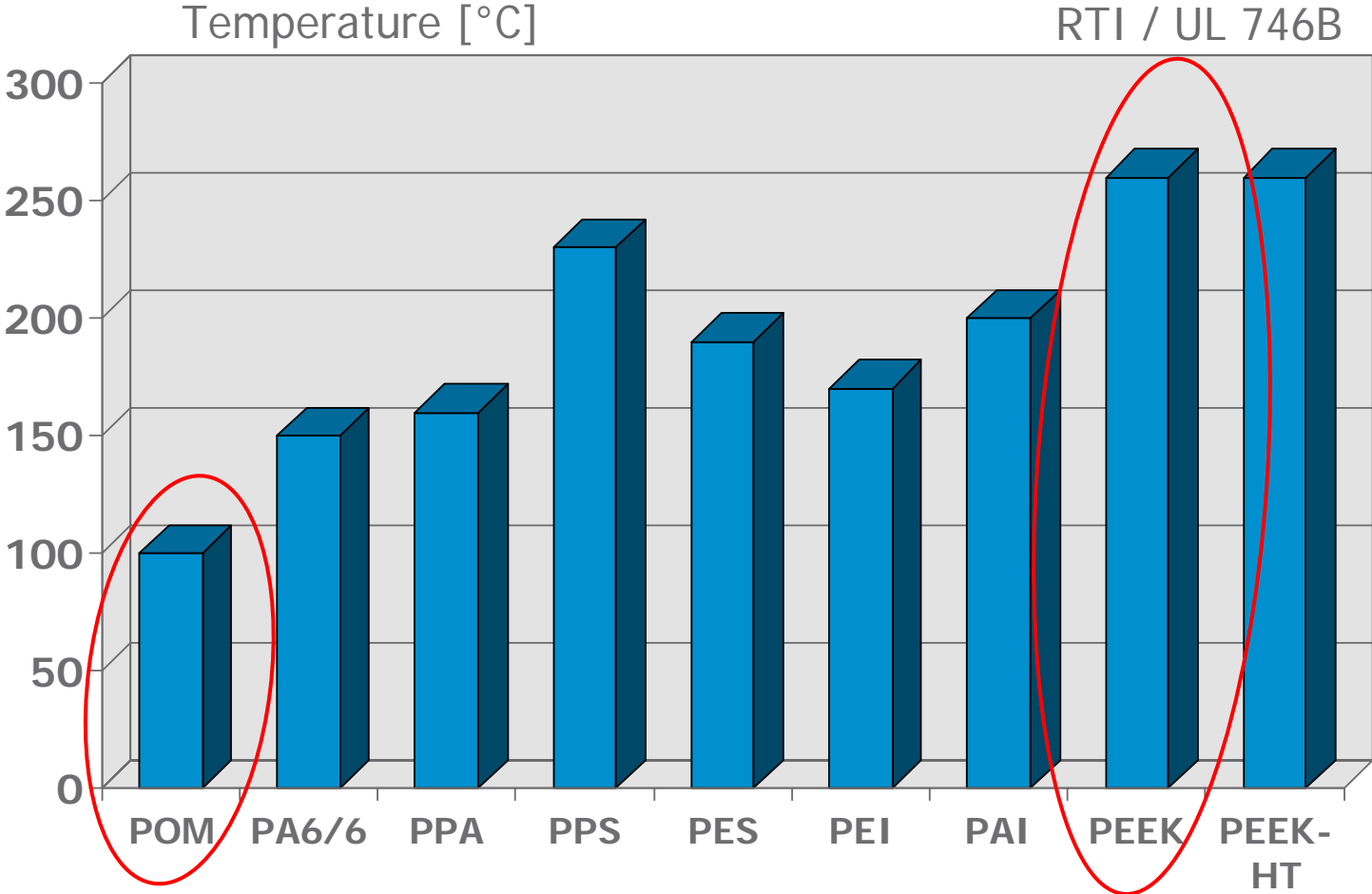

# Mechanical properties

Property	Unit	POM	450G	150CA30
tensile strength	MPa	64	100	224
elongation at break	%	30	100	2
flexural strength	MPa	90	131	355
flexural modulus	GPa	2,7	3,9	20,2
Izod impact strength (notched)	J/m	70	83	90
hardness (Rockwell)	R	98	126	132
thermal expansion	$10^{-5}/^{\circ}\text{C}$	11	4,7	1,5
density	$\text{g}/\text{cm}^3$	1,41	1,32	1,44
HTD 1,8MPa	$^{\circ}\text{C}$	106	152	315

# Flexural modulus / temperature

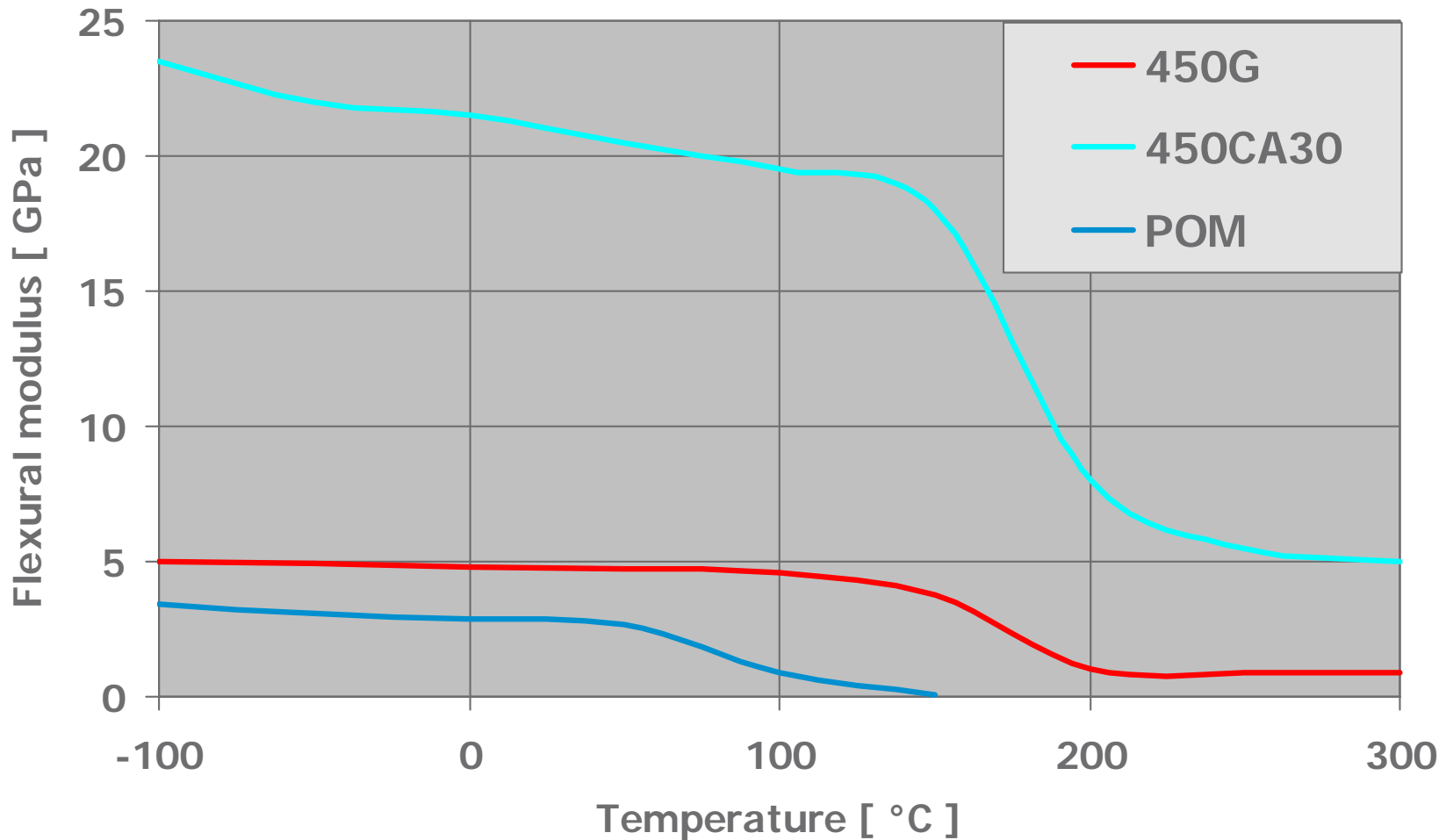

# Tensile strength / temperature

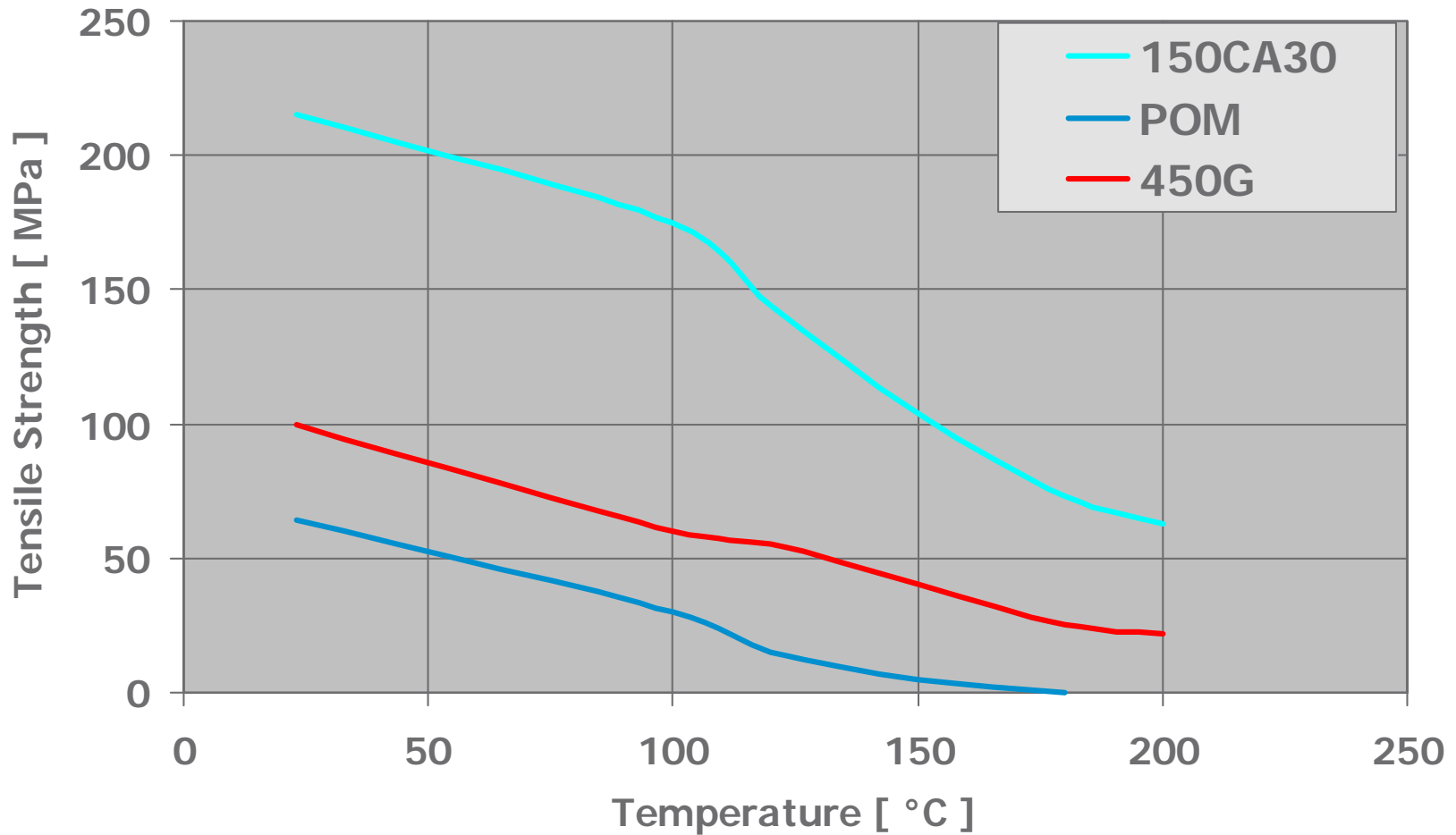

# Flex-Fatigue

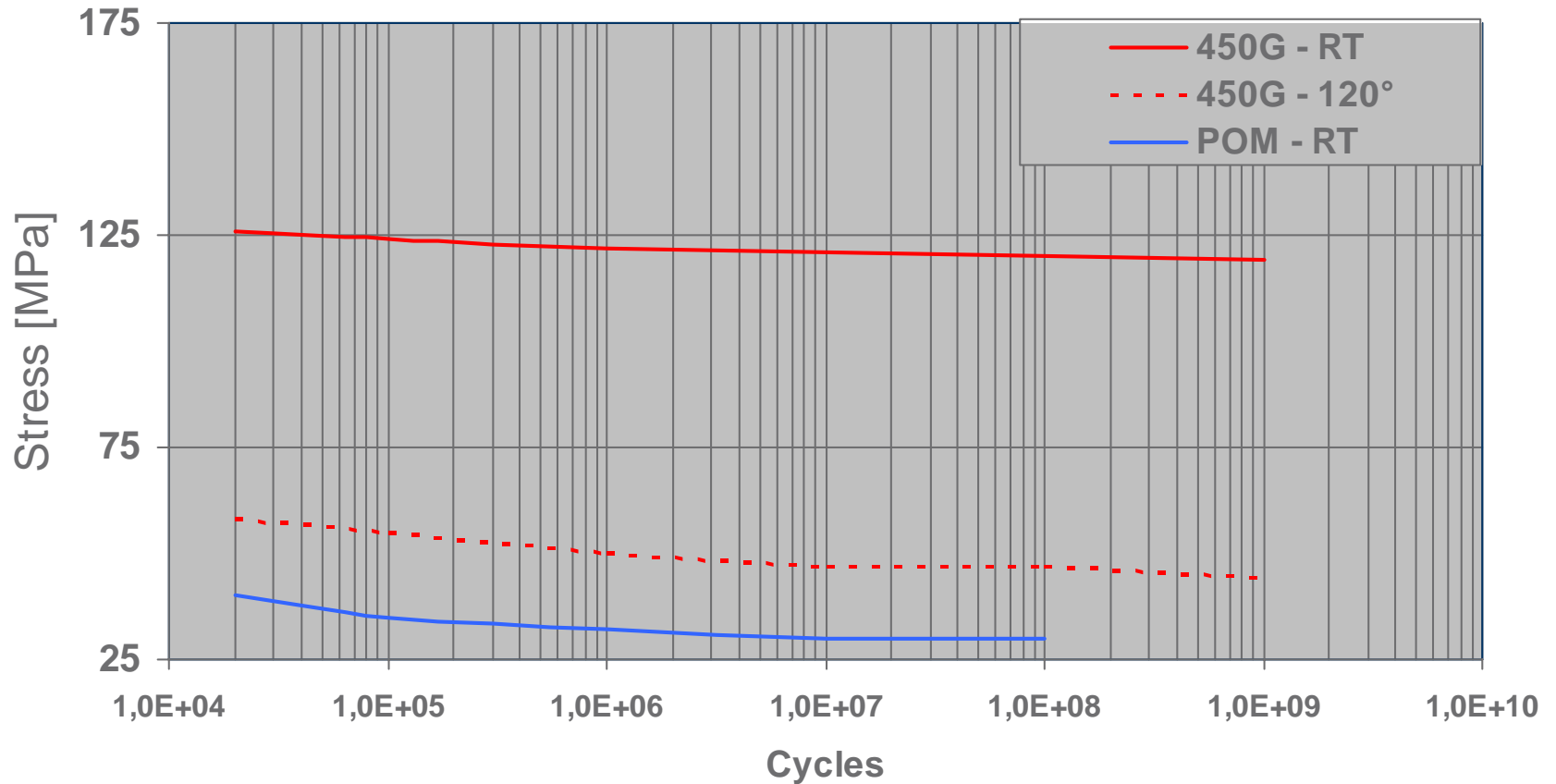

# Tensile strain 450G vs. time (23°C)

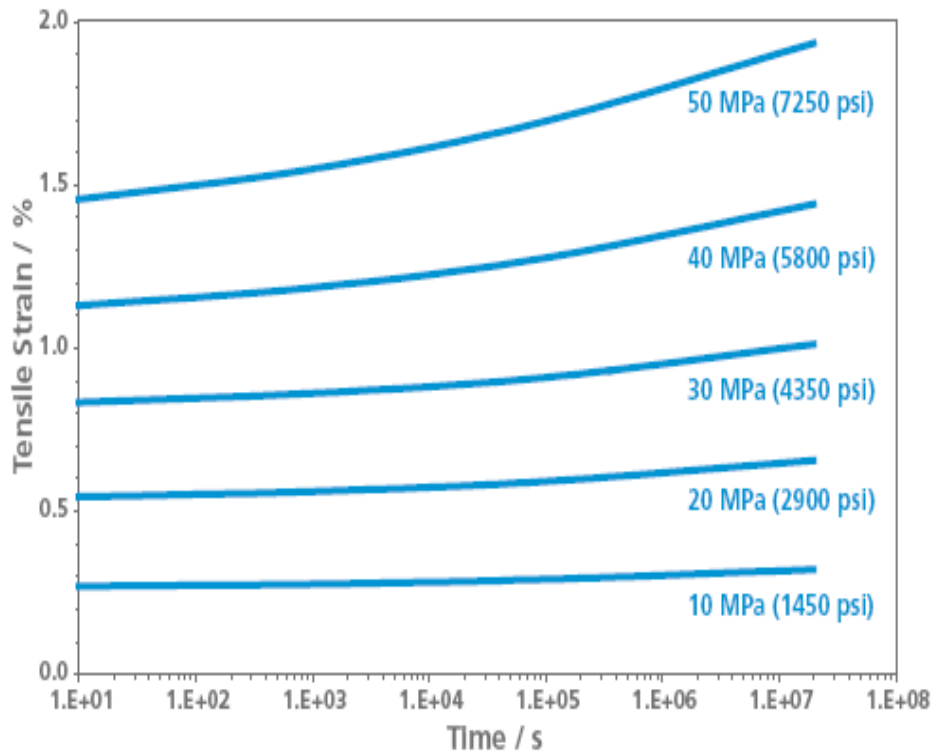
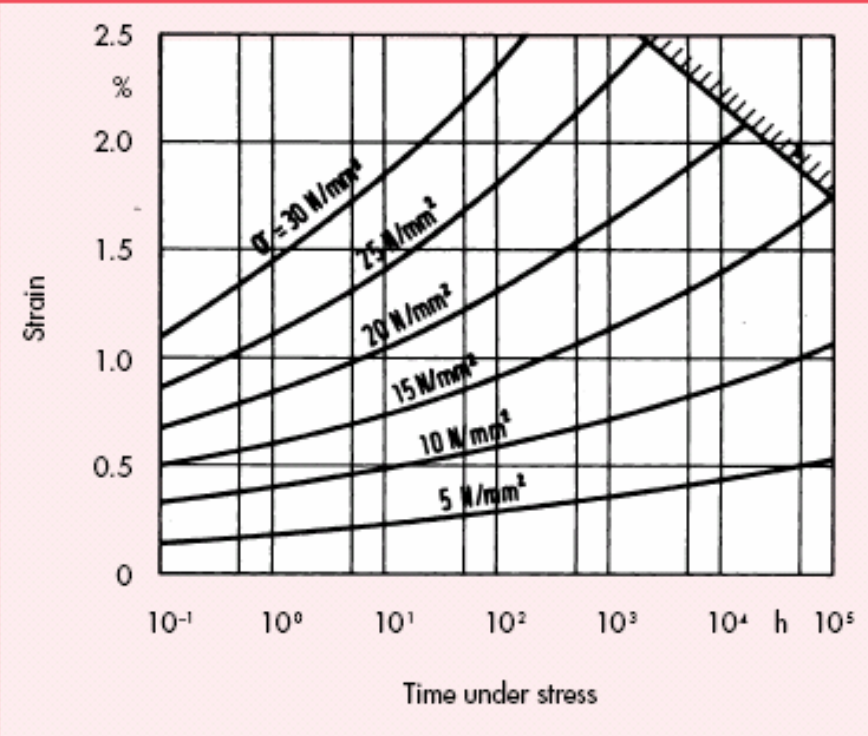
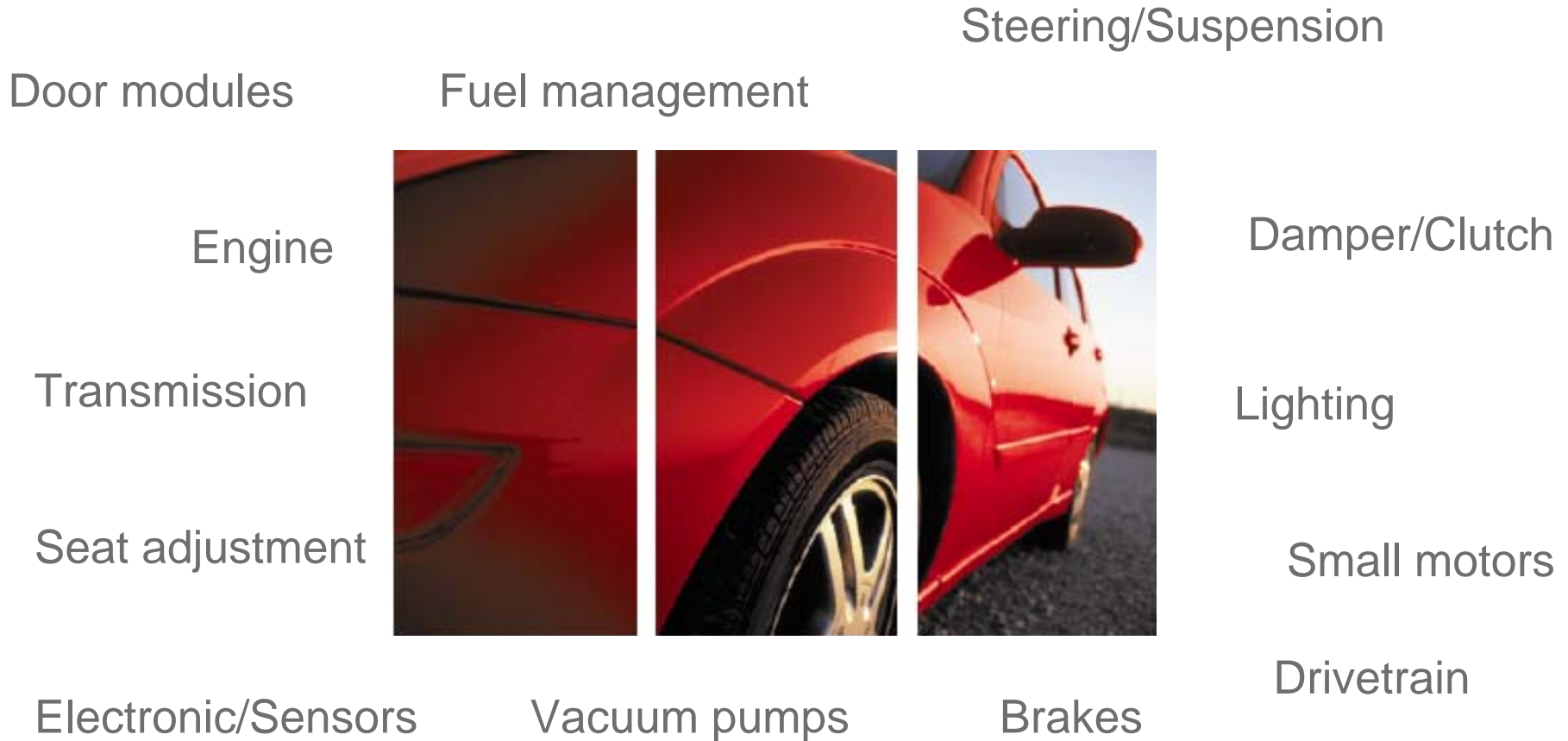

Fig. 6 · Time-strain curves (creep curves) for Hostaform C 9021, measured at 23°C (also a good approximation for the other unmodified Hostaform grades)



# Application Area Overview



# Steering/Suspension - Key requirements

- High mechanical strength
- Temperature resistance from -40°C - +120°C
- Good wear properties
- Impact resistance
- Oil/grease resistance
- Corrosion resistance
- Easy processing

# Steering/Suspension

Steering adjustment  
 • worm gear height adjust



EPS System  
 • worm gear  
 • yoke bearing

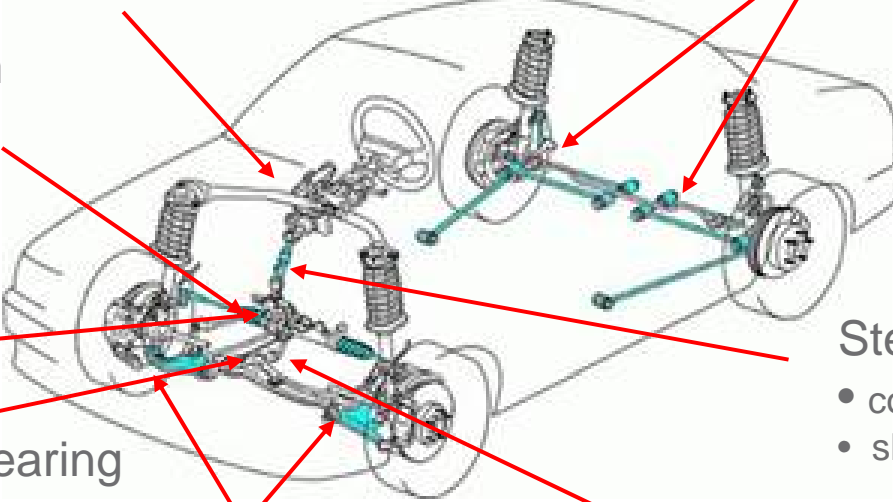

Ball joints  
 • bearing shells



Hydraulic pump  
 • pump coupling



Yoke bearing  
 • sliding foil



Ball joints  
 • bearing shells

Steering column  
 • column sleeve  
 • slider bearing



Active Front Steering System  
 • worm gear

# Suspension



## Details

System: supporting joint  
Application: bearing shell  
Material: 150CA30  
Replacement: POM

## Requirements

- temperature max. 120°C
- CTE  $1,5 \times 10^{-5}$
- compression strength >200 MPa
- coefficient of friction small
- elongation on break >1,0 %

## VICTREX PEEK™ Benefits

- wear resistance
- no clearance over lifetime
- no costs of spare parts

# Suspension



## Details

System: Suspension  
Application: Bearing shells  
Material: PEEK™ 450CA30  
Replacement: Acetal

## Requirements

- › Heat resistance at production process
- › Grease resistance
- › Dimensional stability

## PEEK™ Benefits

- › Wear property
- › Heat resistance
- › Easy processing

# Steering



## Details

System: steering  
Application: sliding foil  
Material: CA30/PTFE10  
Replacement: PA mod.

## Requirements

- temperature max. 140°C
- CTE  $1,5 \times 10^{-5}$
- compression strength >200 MPa
- coefficient of friction small

## VICTREX PEEK™ Benefits

- wear resistance
- no clearance over lifetime
- no costs of spare parts
- loads are too high for Nylon

# Steering



## Details

System: steering  
Application: pump coupling  
Material: 450CA30  
Replacement: powdered metal

## Requirements

- temperature max. 140°C
- CTE  $1,5 \times 10^{-5}$
- compression strength >200 MPa
- coefficient of friction small

## VICTREX PEEK™ Benefits

- wear resistance
- no clearance over lifetime
- no costs of spare parts
- loads are too high for Nylon

# Steering

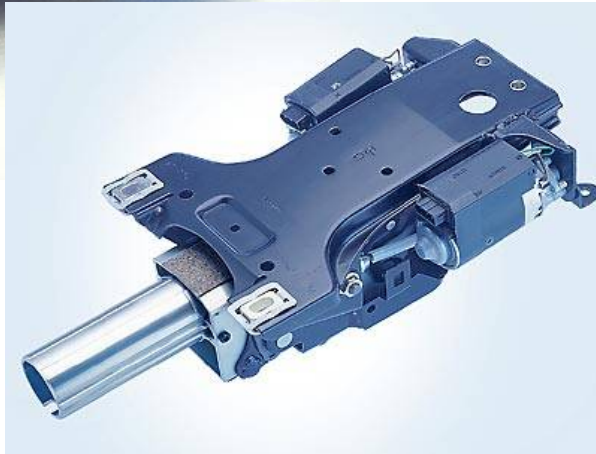

## Details

System : Steering adjust  
Application: spindle nuts  
Grade: PEEK™ 450 G

## Requirements

- max. 80°C,
- high wear resistance
- high ductility
- high creep resistance

## PEEK™ Benefits

- forces down from 40 -> 15 N/cm
- high impact resistance
- cost reduction

# Steering



## Details

System: steering column  
Application: sleeve  
Material: PEEK™ 151G

## Requirements

- temperature max. 140°C
- high impact 1.000°/s
- no dimensional changes
- minus temperature resistance

## PEEK™ Benefits

- wear resistance
- noise reduction
- high ductility
- no moisture absorption

# Steering



## Details

System: steering column  
Application: slider bearing  
Material: PEEK™ 151G

## Requirements

- temperature max. 140°C
- high impact 1.000°/s
- no dimensional changes
- minus temperature resistance

## PEEK™ Benefits

- wear resistance
- noise reduction
- high ductility
- no moisture absorption

# Steering References



Mercedes-Benz



PASSION • INNOVATION • PERFORMANCE



# Disclaimer

“Victrex makes no representations and gives no warranties or undertakings (i) as to the suitability or otherwise of the Materials for use in the manufacture of products by Buyer or any other application or (ii) as to the ownership, validity or subsistence of any intellectual property that may subsist in the Materials or in any application or use thereof. It shall be the sole responsibility of the Buyer to determine the suitability of the Materials for use in the manufacture of products by Buyer or any other application and any use that the Buyer may make of the Materials is at the Buyer’s own risk.”